

## SECME Mousetrap Car Design Competition – Middle and High School Grades 6 – 12

### SECME Mousetrap Car Competition Description

Mousetrap Car Incorporated (MTC Inc) has tasked you with creating a new and innovative Mousetrap Car. The project manager is looking for you to create a Mousetrap Car that can travel the longest distance. However, they challenge you to make this mousetrap car with a bail length of 15.24 centimeters (6 inches) or less.

Each SECME team is required to create an **engineering notebook** and a **presentation** as part of the design process. No video is required since teams in this category, mousetrap car middle and high school division, will present in person in regional and national competitions.

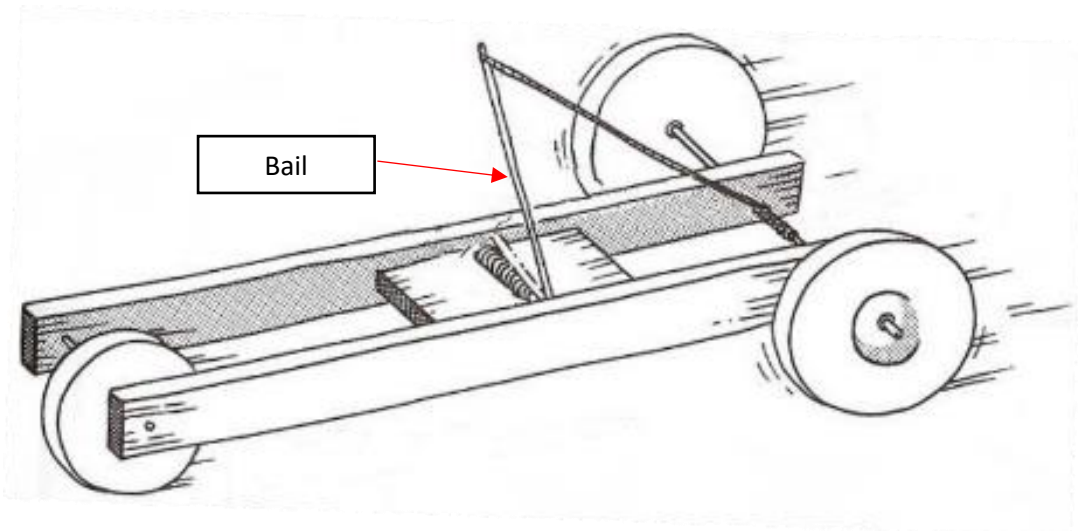

## SECME Mousetrap Car Competition Requirements:

### 1. Materials

- a. Teams **MUST** use a standard mousetrap with dimensions of 9.8 cm (3.86 in) by 4.5 cm (1.77 in) and has only ONE spring
  - i. You **CAN REMOVE** the locking lever and baithook and you **CAN ALTER** the bail

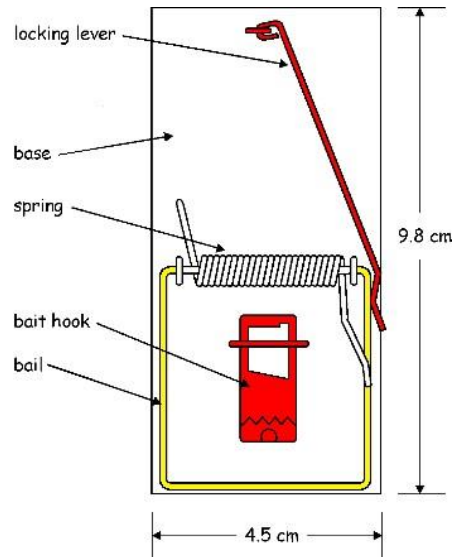

- b. Teams **CANNOT** use 3D-printed materials of any kind in their mousetrap cars.
- c. Teams **MUST** include pictures of their materials in their Engineering Notebook.
- d. **All DONATED** materials **MUST** be documented of where the materials were obtained.

### 2. Construction

- e. The spring from the mousetrap is the **ONLY** power source for your team's mousetrap car.
- f. You **CANNOT** alter the spring in any capacity for your design.
- g. The mousetrap car's bail arm must **not exceed 15.24 cm (6 in)** in length.

### 3. Cost

- h. The **TOTAL** cost of the mousetrap car should not exceed **\$10.00**.
- i. **DO NOT** include the cost of the basic mousetrap in your materials list.
- j. Recycled and donated materials should **NOT** be included in the total budget but **DO** show documentation of how you obtained the material.

## Process Map

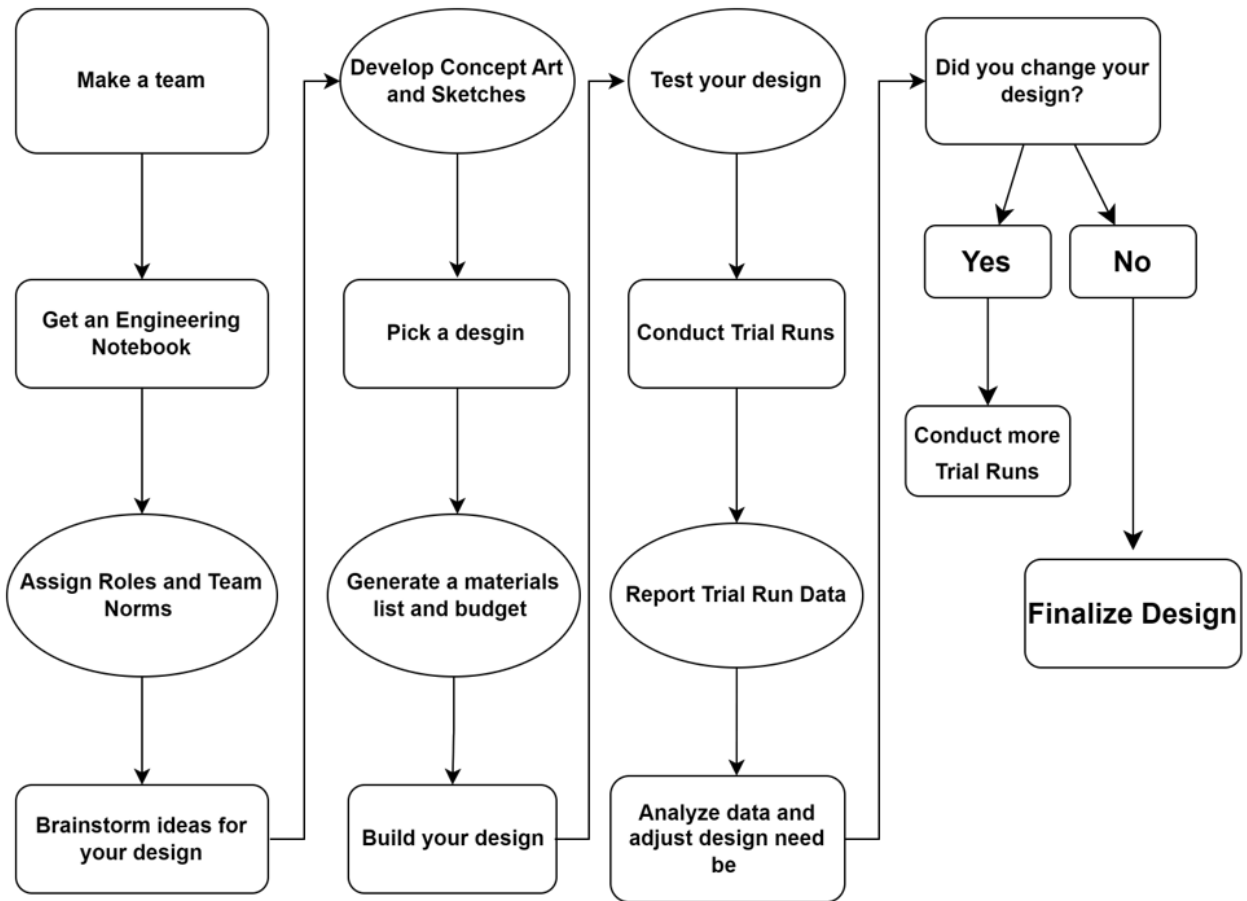

## SECME Engineering Notebook

The SECME Engineering Notebook will allow your team to show all your hard work. Below, you will see the requirements for your team's engineering notebook. The engineering notebook must be completed in a physical notebook, for example, a composition notebook.

### Cover Page

- SECME Team Name
- Team's Competition Type and Division
- Each team member's name and grade
- School Name and District Name
- School City and State
- Name and Email of team's representative (coordinator or teacher)

### Table of Contents

- Including headings and page numbers

### SECME Team Norms and Team Roles

- Each team needs to create a set of Team Norms and Team Roles that should be placed directly after the table of contents.
  - Team norms are a set of rules or operating principles that shape team member's interactions.
  - Create 5-10 team norms
  - Example: Treat each team member with respect
- Team Roles should be assigned based on each team member's strengths. Each team is REQUIRED to use these roles. If you have a team with less than 4 team members you can consolidate these roles. The SECME Team Roles include the following:
  - Team Lead: This team member is responsible for overseeing management of the project and its success. The team lead will make sure the team is on track to complete the project on time and under budget. They communicate with their coordinator/instructor for all questions and concerns.
  - Scribe: This team member is responsible for keeping the Engineering Notebook up to date and taking any meeting notes. This person should have clear and legible handwriting. They also will need to communicate with each team member to collect information and work for the Engineering Notebook.
  - Engineering Lead: This team member is responsible for maintaining the team's original mousetrap car design and creating any relevant technical drawings for the Engineering Notebook.
  - Data Analyst: This team member is responsible for recording all data for the team's original mousetrap car and its trial runs. This team member is also responsible for recording the dimensions of the mousetrap car and documenting

the materials list. The data analyst will use the materials list to collaborate with the team lead on the budget.

#### Brainstorm

- Include ALL ideas your team considered in the brainstorming process.

#### Concept Art/Sketches

- ALL preliminary sketches that were used in the developmental stages of your design process.

#### Materials List and Budget

- Please provide a list of materials used in your design along with pictures of the materials.
- Include cost of **ALL** materials **EXCEPT** recycled materials
  - For recycled materials include documentation of where your team obtained the materials.
- Include photos or copies of receipts for **ALL** purchased materials.
- Include final cost of **ALL** materials.
- Include the total money saved by your team.

#### Technical Drawings

- The team's technical drawings are required to show the front, side, and top views of the mousetrap car design.
- Label all parts of mousetrap car design.
- Label all relevant dimensions of the mousetrap car design (For example, Length, Width, or Height).
- Label all units of mousetrap car measured in centimeters.
- The technical drawings can be hand drawn or created digitally using a CAD program.
- Ink pens, pencils, or markers may be used.

#### Photos

- Include photos of the mousetrap car design front, side, and top views.

#### Trial runs

- Please include documentation of each trial run and notes/observations from each of the trial runs of the mousetrap car design.
- Indicate which version of your mousetrap car design you used for each trial run. (For example, Trial Run – Design 1 – Test 1)
- Include **ALL** mousetrap car design trial runs.

## Meeting Notes

- Include **ALL** meeting notes for mousetrap car design.
- **ALWAYS** include the **DATE** and **TIME** of each meeting for mousetrap car design.

## Trial Runs

Your team will use the distance traveled to understand the performance of your mousetrap car design. Your team will be able to use this data to evaluate the effects of changes made to your mousetrap car design. Each version of the mousetrap car design requires a minimum of 3 trial runs. A new set of trials must be documented in the Engineering Notebook each time a new design change is made to the car. You must list a minimum of two sets (a total of 6) of trial runs: one set for the original design, and another set for the final design. You may choose to redesign your mousetrap car multiple times, but a set of 3 trial runs must be shown each time.

When documenting your mousetrap car trial runs, record your mousetrap car's:

1. Distance traveled measured in centimeters (where forward motion is denoted as positive distance and backward motion is denoted as negative distance)
2. Include notes about the mousetrap car's performance.
3. Include a hypothesis (or prediction) of what your team thinks will happen during the trial run given the new changes made by the team.

Additionally, your team will need to include a statistical analysis of your mousetrap car's performance. Include the following data from your team's tests:

- Average distance traveled from trial runs.
  - $\bar{d} = \frac{d_1 + d_2 \dots + d_n}{n}$
  - $\bar{d}$  is the average distance traveled from trial runs measured in centimeters.
  - $d$  is the distance traveled from a trial run measured in centimeters.
  - $n$  is the number of trial runs performed by the team's mousetrap car.

## Presentation

The Presentation will allow your team to showcase your work in a presentation format. You may use the platform of your choice (PowerPoint, Google Slides, Canva, etc.) We hope that through this presentation your team will be able to further showcase your mousetrap car design and all the hard work you have done. Please use the information below as a template for your presentation.

### Title Slide

- SECME Team Name
- Team's Competition Type and Division
- School Name and District Name
- School City and State
- Name and Email of team's SECME coordinator

### About Your Team Slide

- Team Photo
- Team members names, grade levels, and team roles.
- Years involved with SECME.

### Brainstorm and Sketches

- Include the final ideas (you do not need to include all your ideas) your team considered in the brainstorming process
- Explain why you **DID NOT** use them in your final design
- Include any sketches you used in your brainstorming process

### Drawings of the Final Design

- Include a photo of your sketch of the final design (this is **NOT** your technical drawing)
- Explain what you used from your brainstorming process and why you included it

### Materials list and Budget

- Provide a list of **ALL** materials used in your design along with pictures of the materials
- Include cost of **ALL** materials **EXCEPT** recycled materials
- For recycled materials include documentation of where you obtained it
- Include a photo of receipts for **ALL** purchased materials
- Include final cost of all materials.

## Technical Drawings

- The team's technical Drawings are required to show the front, side, and top views of the design
- Label all parts of design and explain their functionality
- Label all relevant dimensions of the design in centimeters (for example, length, Width, or Height)
- Explain why you choose your mousetrap car's bail length
- Include a color photo of your mousetrap car next to the technical drawing

## Trial Runs

- Include data from your most recent trial run on your final design

## Conclusions and Future Recommendations

- Provide your team's conclusion on your design process and any recommendations you have to better your design in the future (For example, if cost were not a constraint)



## Submission Requirements and Scoring

1. Longest Distance Traveled – 50%
  - This score is determined based on performance at the regional competition.
  - Distance Score =  $\left(\frac{\text{team distance}}{\text{max distance}}\right) \times 100\%$
2. Engineering Notebook – 30%
  - The notebooks will be evaluated by judges at the competition. You must bring your physical notebook to receive a score.
3. Presentation – 20%
  - The presentation must be submitted as a PDF with the file name “SECME\_MTC\_Presentation\_Your Division\*\_Your School Name”.
    - o \*Your Division is either “High” or “Middle”

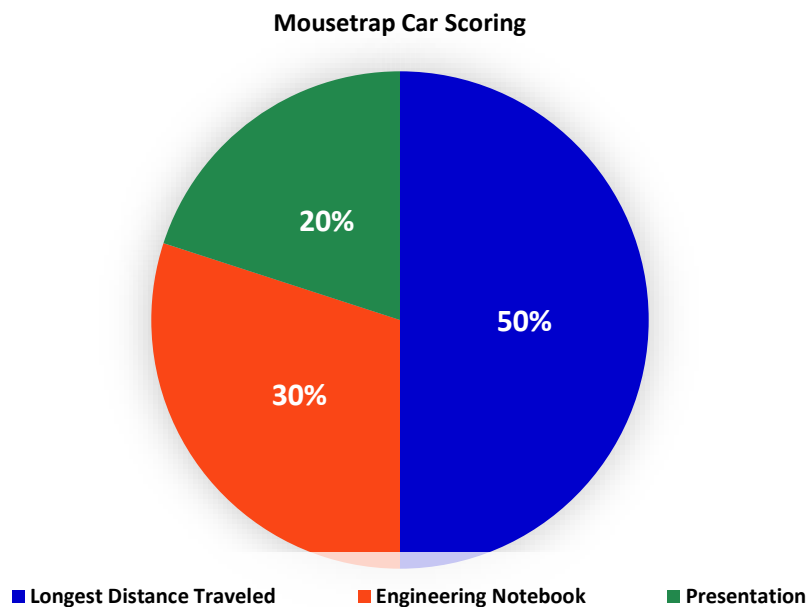

## Questions

If your team has any questions, please feel free to contact our team at [SECME@ENG.UFL.EDU](mailto:SECME@ENG.UFL.EDU)